

# Machinery list and specifications

**Professional danish designed and produced machinery,  
affordable prices.**

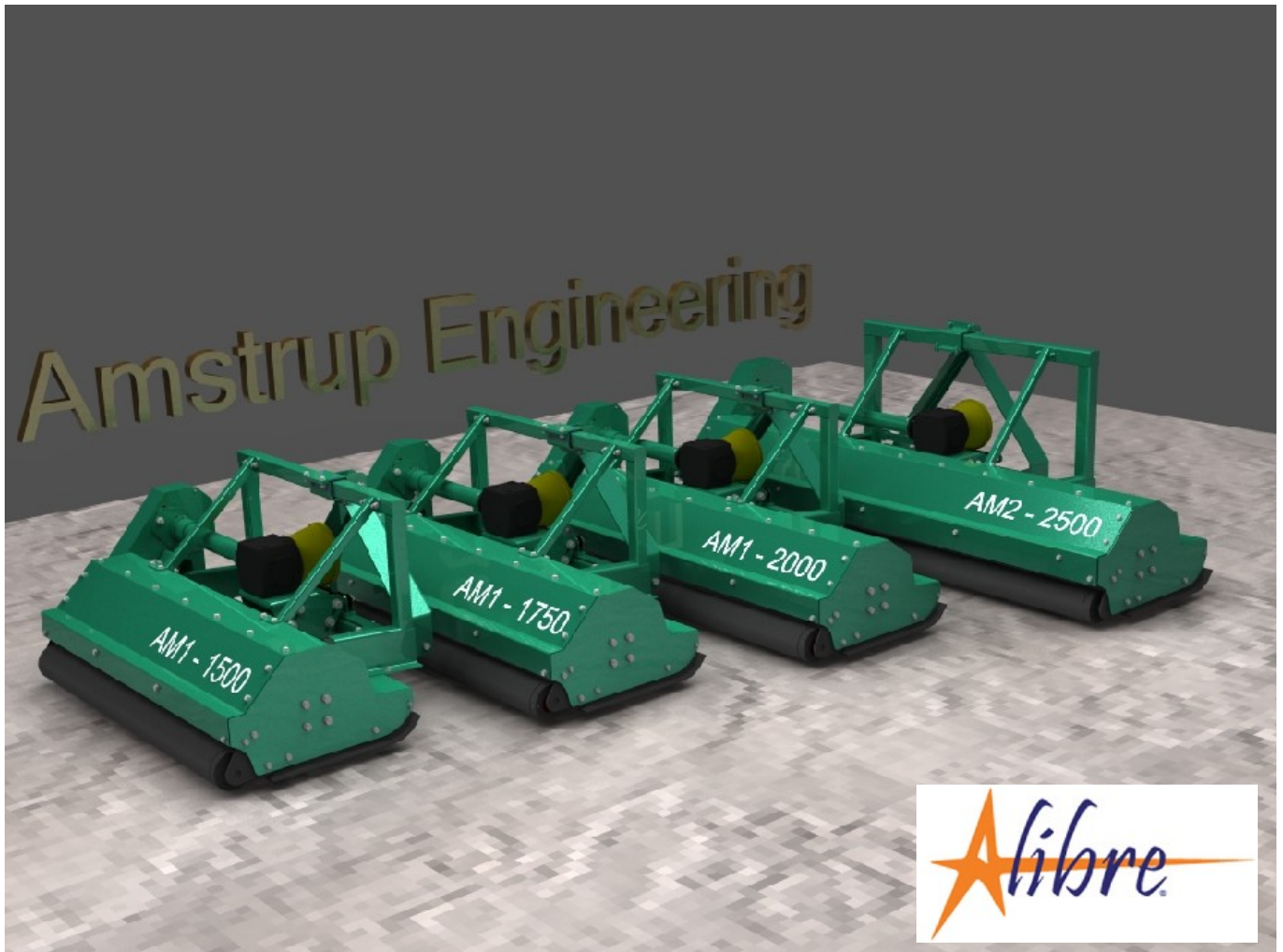

All machinery is designed in Alibre design.

[www.nettocad.dk](http://www.nettocad.dk)

## **Amstrup Engineering**

Damhusvej 55

7660 Bækmarksbro

tlf. +45 61337807

[www.a-engineering.dk](http://www.a-engineering.dk)

[mail@a-engineering.dk](mailto:mail@a-engineering.dk)

# Flail Mower Model AM1 (20-60hp)

Flail Mower model AM1 is designed for the professional user. It can be used for all green areas in the Agricultural and Forestry industry for grass cutting, crop residues and wood pieces up to 1 cm. Its design is heavy and made for intensive use.

## Standard equipment:

Gearbox 540 rpm with freewheel clutch, mechanical side offset to the three point hitch system category I, adjustable side skids, metal fenders, adjustable rear roller, hammer 430 gram for grasscutting.

## Optional equipment:

Hydraulic side offset, front mounting, rear cover with hinge, cast hammer 850 gram for cutting of material till 1 cm.

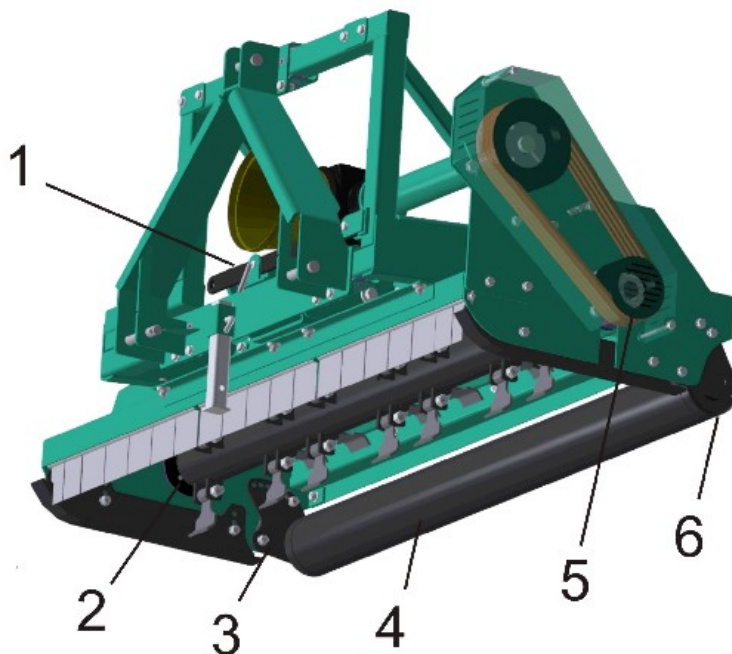

1- Mechanical side offset for the three point hitch. Hydraulic cylinder for hydraulic side offset. (Optional equipment which can be mounted later.)

2- Heavy Spherical roller bearing in the shaft for blades for long lifetime

3- Adjustable roller

4- Heavy roller  $\varnothing$  140 mm

5- Heavy belt drive and ventilated protection.

6- Heavy Spherical roller bearing in the roller for long lifetime.

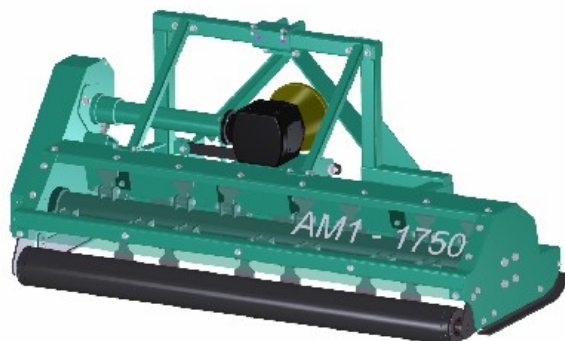

Removeable back cover. Optional rear cover with larger opening.

# Flail Mower Model AM1 - Dimensions and Weight

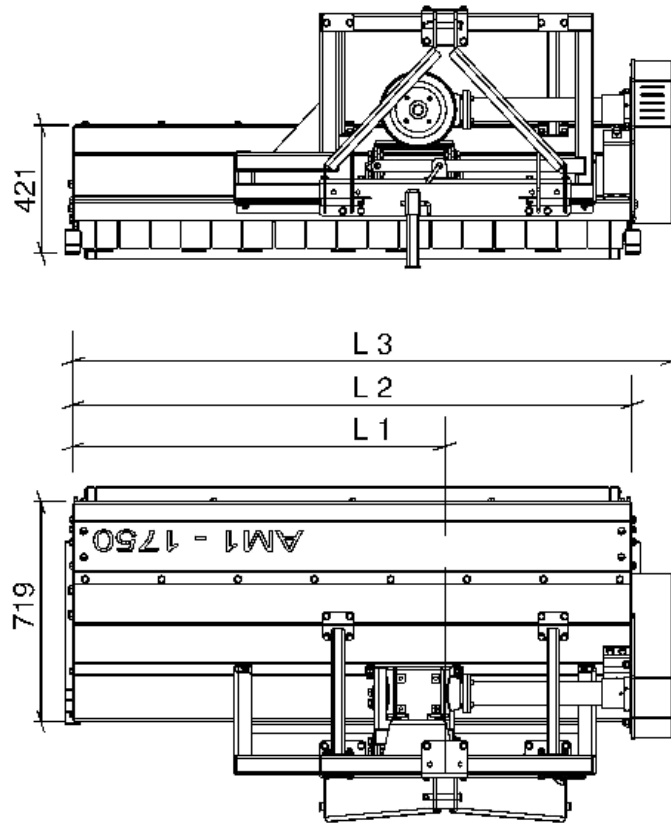

Model AM1	min/max hk	weight	dimension L1	dimension L2	dimension L3	hammer 430 gram	cast hammer 800 gram
1250	20 / 35	270	718	1330	1462	20	20
1500	25 / 45	394	968	1580	1712	24	24
1750	30 / 50	420	1218	1830	1962	28	28
2000	45 / 60	450	1468	2080	2232	32	32

## Pricelist

	Standard version	Extra charge for cast hammers	Extra charge for hydraulic side offset	Extra charge for front mounting
Model AM1 - 1250	3800	54	391	405
Model AM1 - 1500	4000	65	391	405
Model AM1 - 1750	4250	76	391	405
Model AM1 - 2000	4700	87	391	405

Side offset 200 mm

Prices are € net prices ab. factory + VAT

# Flail Mower Model AM2 (50-80hp)

---

Flail Mower model AM2 is designed for the professional user. It can be used for all green areas in the Agricultural and Forestry industries for grass cutting, crop residues and wood pieces up to 2,5 cm. Its design is heavy and made for intensive use.

## **Standard equipment:**

Gearbox 540 rpm with freewheel clutch, mechanical side offset to the three point hitch system category II, adjustable side skids, metal fenders, adjustable rear roller, hammer 500 gram for grasscutting.



## **Optional equipment:**

Hydraulic side offset, front mounting, rear cover with hinge, cast hammer 1300 gram for cutting of material till 2,5 cm.

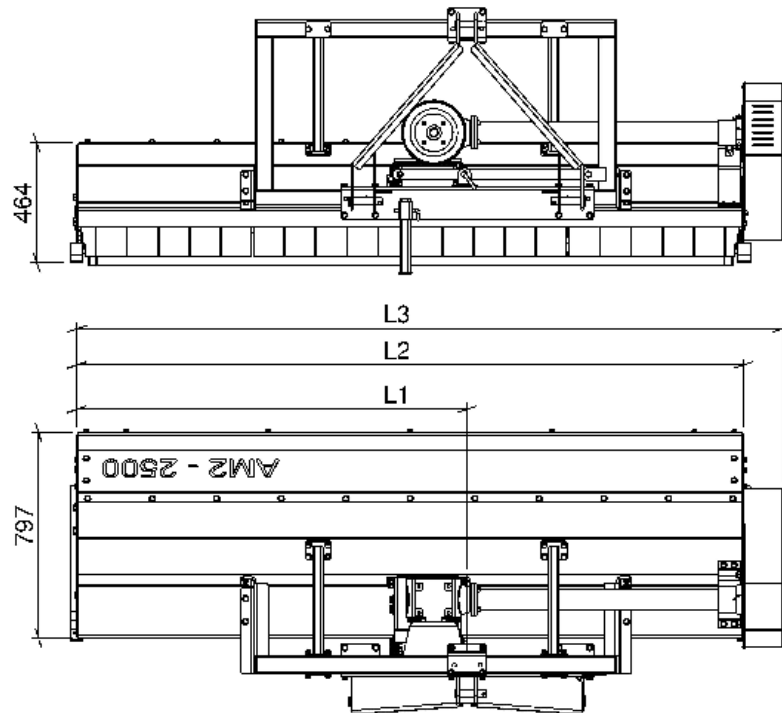

# Flail Mower Model AM2 - Dimensions and Weight



Model AM2	min/max hk	weight	dimension L1	dimension L2	dimension L3	 hammer 500 gram	 cast hammer 1300 gram
2000	50 / 65	541	1334	2076	2234	32	32
2500	60 / 80	615	1511	2582	2733	36	36

## Pricelist

	Standard version	Extra charge for cast hammer	Extra charge for hydraulic side offset	Extra charge for front mounting
Model AM2 - 2000	4990	130	391	405
Model AM2 - 2500	5260	146	391	405

Side offset 250 mm

Prices are € net prices ab. factory + VAT

